



ACCEPT ONLY THE BEST

Skid Unit Mounting Instructions

Skid Base dimensions 48" x 96"

- 1- Put the skid unit on the truck bed. Use a forklift with long forks to support most of the tank floor.



- 2- Center the skid unit in the middle of the vehicle.
- 3- Drill holes on the truck where the skid unit already has holes (6 holes) by using a Three Handle Electric Drill and a 5/8" drill bit. If the holes are not accessible, use a long drill bit to help you reach the space needed (see page 4 for holes positioning dimensions).



C.E.T. Fire Pumps Mfg. This handbook is subject to change without notice, Contact your local C.E.T. dealer or C.E.T. direct to ensure you have the latest version.

- 4- We recommend to bolt the tank through a channel of the flat bed truck if possible. If not, we recommend to add reinforcement by installing two metal plates ¼” thick underneath the truck. Place one in front and one at the back of the skid unit and mark the plates where’s the tank holes are located. Then drill those marks using drill bit 5/8”.



- 5- Prepare six (6) stainless steel flat washers ½” on six (6) stainless steel hexagonal bolts ½” and put anti-seize on it before bolting the skid unit. Then place your six (6) bolts in the six (6) holes.



- 6- Put six (6) stainless steel flat washer before screwing six (6) stainless steel hexagonal nylon nuts on the bolts underneath the truck.
- 7- At this step, you need to be two (2) persons. The first one must be underneath the truck to hold the nuts with a key. The second one must use an impact gun to screw bolts on the skid unit. Make sure the bolts are enough long to get a minimum of 3 threads of the bolt protrude the nuts. *The 1/2" stainless steel bolts are recommended to be torqued at 43 lbs-ft.*



MOUNTING HOLES

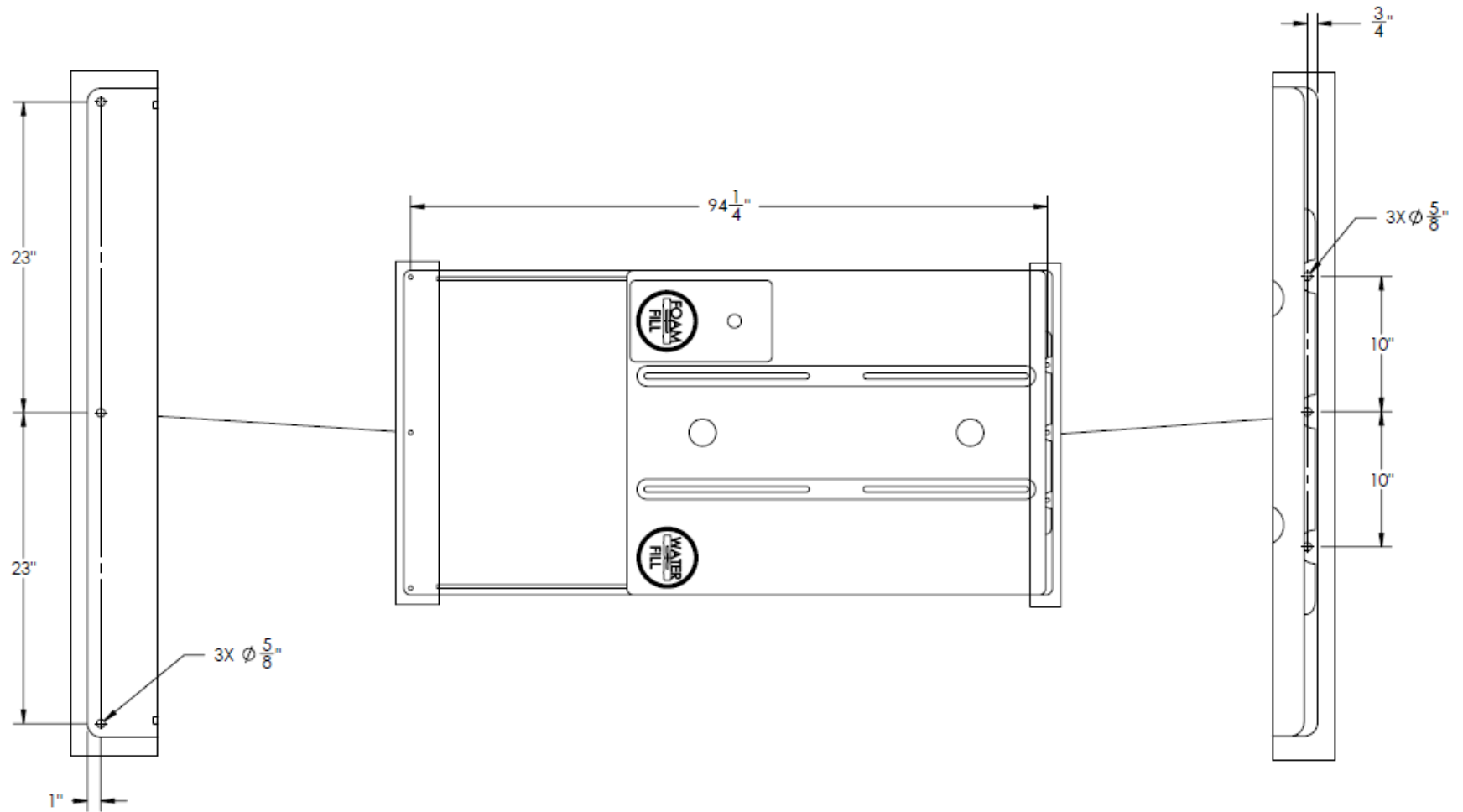

For repair or questions about warranties, please contact your local C.E.T. fire pumps dealer.

E-mail : service@fire-pump.com

Tel. : 1-450-568-2719

Fax : 1-450-568-2613

**C.E.T. fire pumps MFG
75, Hector Street, C.P.90
Pierreville, QC
J0G 1J0**



ACCEPT ONLY THE BEST

For more information on our products go to

www.fire-pump.com



C.E.T. Fire Pumps Mfg. This handbook is subject to change without notice, Contact your local C.E.T. dealer or C.E.T. direct to ensure you have the latest version.